

GPS100 Series

Air Pressure Switch

Application:

GPS100 Series pressure switches are especially designed for high volume OEM market. Typical applications include boilers, hot water heaters, HVAC and other industrial equipments.

These switches could be customized set points and can be used to positive pressure sensing, negative pressure sensing and differential pressure sensing.

A sensitive high reliability snap action switch is used as the main switching element. The snap action switch can provide a high switching capability up to 16A 125/250VAC.

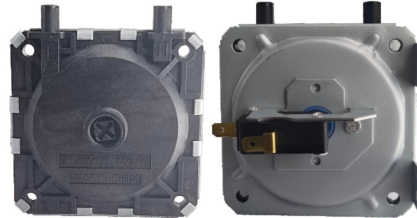

Specifications:

Set Point:

Set Point Range: 10-1500Pa
 Operating Pressure Range: 25-1500Pa
 Switch off Pressure Range: 10Pa Min
 Fixed set-point calibrated in Factory.

Maximum Pressure Allowed: 4000pa.

Switch Rating
 0.1A 125/250VAC, 3A 125/250VAC
 5A 125/250VAC, 16A 125/250VAC
 (Resistive Load)
 Switching Element
 Snap Action Switch
 SPDT, SPST-NO, SPST-NC
 Measured Media: Air
 Operating Temperature: -40~+90°C

Installation & Sample Line Connection

Mounting:

Always mount with the diaphragm in vertical plane in order to maintain the specified operating point fixed in the factory.

Avoid mounting with sample-line connections directed upward.

Positive Pressure Sensing Only:

Connect the sample-line to H while L remains open to the atmosphere.

Negative Pressure Sensing Only:

Connect the sample-line to L while H remains open to the atmosphere.

Differential Pressure Sensing:

Connect the higher pressure sample line to H and the lower pressure sample-line to L.

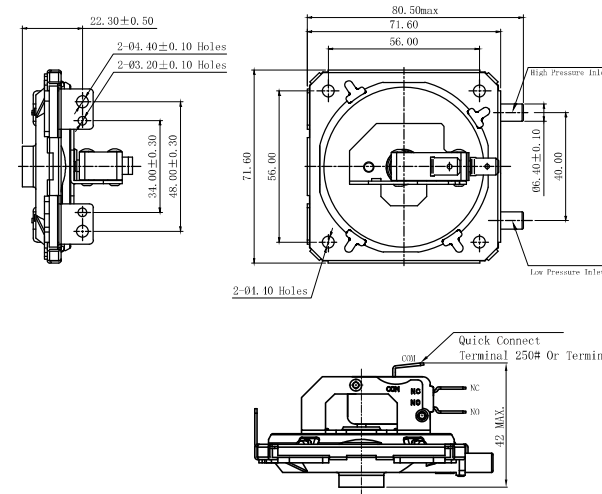
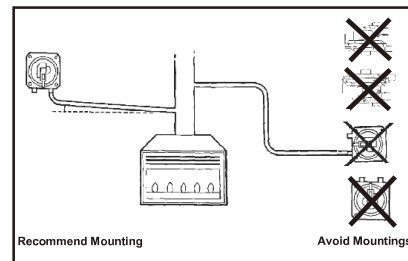
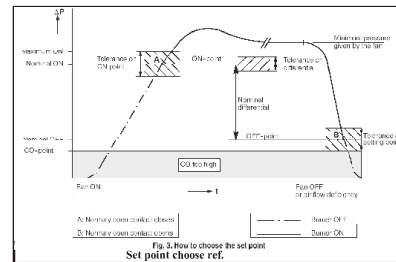
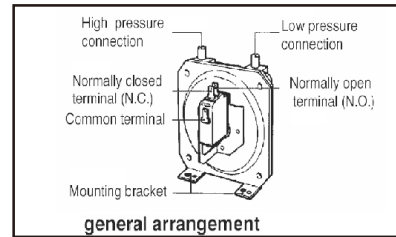

Assembled Shape:

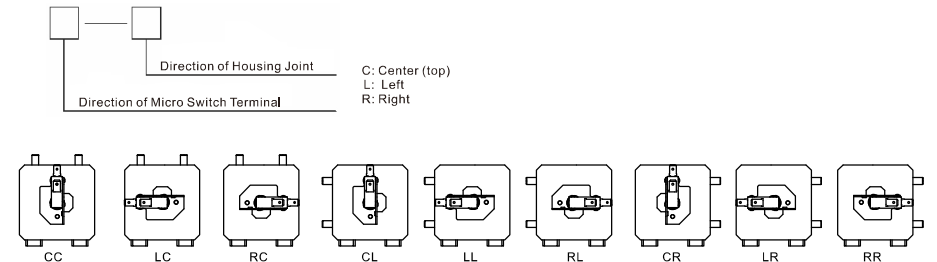

Pressure Conversion Table

1Pa=	0.01	mbar
(pascal N/m²)	1x10 ⁻⁷	bar
	102x10 ⁻⁷	kg/cm²
	0.102	mm H2O
	0.0075	mm Hg
1mbar=	100	pa
(millibar)	0.001	bar
	102x10 ⁻⁴	kg/cm²
	10.2	mm H2O
	0.750	mm Hg
	0.0145	psi
1bar=	100 000	pa
	1000	mbar
	1.02	kg/cm²
	10 200	mm H2O
	750	mm Hg
	145.038	psi
1kg/cm²=	98100	pa
kilogram per cm²	981	mbar
	0.981	bar
	10 000	mm H2O
	750	mm Hg
	142.233	psi
1mm H2O=	9.81	pa
(mm water gauge)	0.981	mbar
	0.001	bar
	0.0736	mm H2O
	0.001422	psi
1mm Hg=	133.3	pa
(mm mercury)	1.33	mbar
	0.00133	bar
	0.001369	kg/cm²
	13.69	mm H2O
	0.01934	psi
1psi=	6895.06	pa
(pounds per sq inch)	68.95	mbar
	0.06895	bar
	0.07031	kg/cm²
	703.01	mm H2O
	51.717	mm Hg

GPS100 Series Air Pressure Switch Ordering Instruction

GPS100	3P	80	CC	1	C	Z	G	L	T001	U
Switch Type	Off Pressure Set Point	On Pressure Set Point	Assembled Shape	Electrical Rating	Terminal Type	Circuitry	Color of Micro Switch	Pressure Type	Custom Code	LOGO
GPS100 Series Air Pressure Switch	According to Customer's Requirements	According to Customer's Requirements	Refer to "Assembled Shape"	1 < 0.1A	C 6.30x6.30mm 0.250"x0.402" Quick Connect Terminals	C SPST-NC	G Grey	H Positive Pressure	General	U Unionwell
				2 > 0.1A and ≤ 5A	E 4.70x4.25mm 1.875"x1.670" Quick Connect Terminals	P SPST-NO	B Black	L Negative Pressure	TO 01 Customized according to requirements, format is T+serial number+XX, for example: T001	... Other
				3 > 5A and ≤ 16A		Z SPDT				
				4 > 16A						